

CONTACT US

WWW.SAMSONEQUIPMENT.COM

1-800-4-SAMSON

Physical Address:

258 N Armory Rd

Las Cruces, NM 88007

Mailing Address:

P.O Box 353

Fairacres, NM 88033



<https://www.facebook.com/SamsonEquipment/>



https://www.instagram.com/samson_eq/



https://twitter.com/SAMSON_EQ



<https://www.youtube.com/user/samsonequipment>



<https://www.linkedin.com/company/samson-equipment-inc./>

**BOOK
NOW**



**SCAN
FOR
WEBSITE**





ZEBOWZ

CONTENTS

SAMSON STANDARD	4
PROCESS	6
CUSTOM SOLUTIONS	24
CUSTOM BRANDING	25
FLOORING	28
FLEX-RACK.....	32
POWDER COAT & UPHOLSTRY COLORS	38
PRODUCTS	44
TACTICAL	64
FACILITIES	66
SPECS AND WARRANTY	182

S
T
M
E
T
M
O
E



SAMSON STANDARD

With a legacy spanning four decades, Samson has been dedicated to offering Professional Weight Room Solutions to our valued partners. As coaches ourselves, we understand your needs and have built a trusted foundation of expertise and experience. Our qualified team combines industry knowledge and manufacturing prowess, setting us apart from the competition. We pride ourselves on maintaining manufacturing excellence, ensuring exceptional customer satisfaction, and upholding our reputable standing in the industry. Samson Equipment proudly holds the distinction of being the Official Weight Room Supplier of the National Association of Intercollegiate Athletics (NAIA) Whatever your project may be, our team, products, and services guarantee a seamless and successful experience for you.

OUR SALES TEAM

At Samson Equipment, your needs are at the forefront of our mission. We are committed to delivering Professional Weight Room Solutions tailored to each client. We recognize that while the demand for top-notch strength equipment is universal, the specific requirements vary greatly depending on your project. Whether it's for schools, the United States Armed Forces, professional athletic teams, or elite home gyms, our dedicated Samson Equipment team is here to streamline the process for you. Trusting our experts will not only save you time but also spare you from unnecessary hassle and stress.



BRIAN SCHROEDER

DIRECTOR OF OPERATIONS

GSA SALES DIRECTOR

1-800-472-6766 EXT 203

BRIAN@SAMSONEQUIPMENT.COM



SCOTT SCHROEDER

DIRECTOR OF SALES

1-800-472-6766 EXT 202

SCOTT@SAMSONEQUIPMENT.COM



KRISTOFFER KOERPER

SALES SPECIALIST - USA

1-800-472-6766 EXT 207

KOERPER@SAMSONEQUIPMENT.COM

PROCESS

At Samson Equipment, we take pride in leading you through our proven process of weight room project management. We understand the complexities that arise when balancing coaching or administrative responsibilities while embarking on such a venture. With our seasoned expertise and over 40 years of experience, we become your trusted guides, ensuring a smooth and successful journey from start to finish. Let us alleviate your concerns and empower you with our knowledge, as we navigate each step together, delivering a transformative outcome that exceeds your expectations.

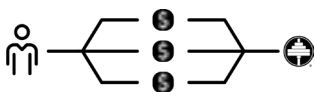

1 MEANS OF PURCHASE

We offer various methods to procure your equipment.

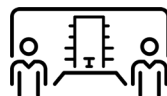

3 PROGRAMMING

The Samson difference involves working with professional guides who understand program design, room layouts and flow of your room.



2 BUDGET

It's important to know your budget. We have many options of flooring and equipment selection to achieve your goals. Don't settle for less than what you deserve.



4 EQUIPMENT SELECTION

Selecting the best equipment to satisfy your needs, wants and budget. Your guide will begin to present you with options and recommendations for your project.

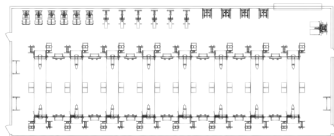

5. 2D LAYOUTS

During this step we will design out the best arrangement for your space until you find a layout that is tailored to you.



7. MANUFACTURING

Your planning turns into a project, and our team of professional fabricators go to work for you!

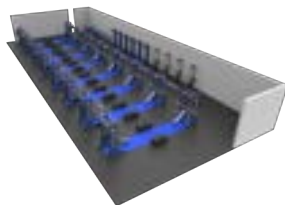

6. 3D LAYOUTS

After getting approval of your 2D layout, we begin to design your 3D renders so you can get an accurate picture of what your room will look like installed.



8. DELIVERY/INSTALLATION

We will determine the best shipping methods and install options for your new facility.

MEANS OF PURCHASE

We understand that our customers share a need for having various means of procurement for their equipment. We offer these various methods in order to provide a high level of customer service and a first class experience.



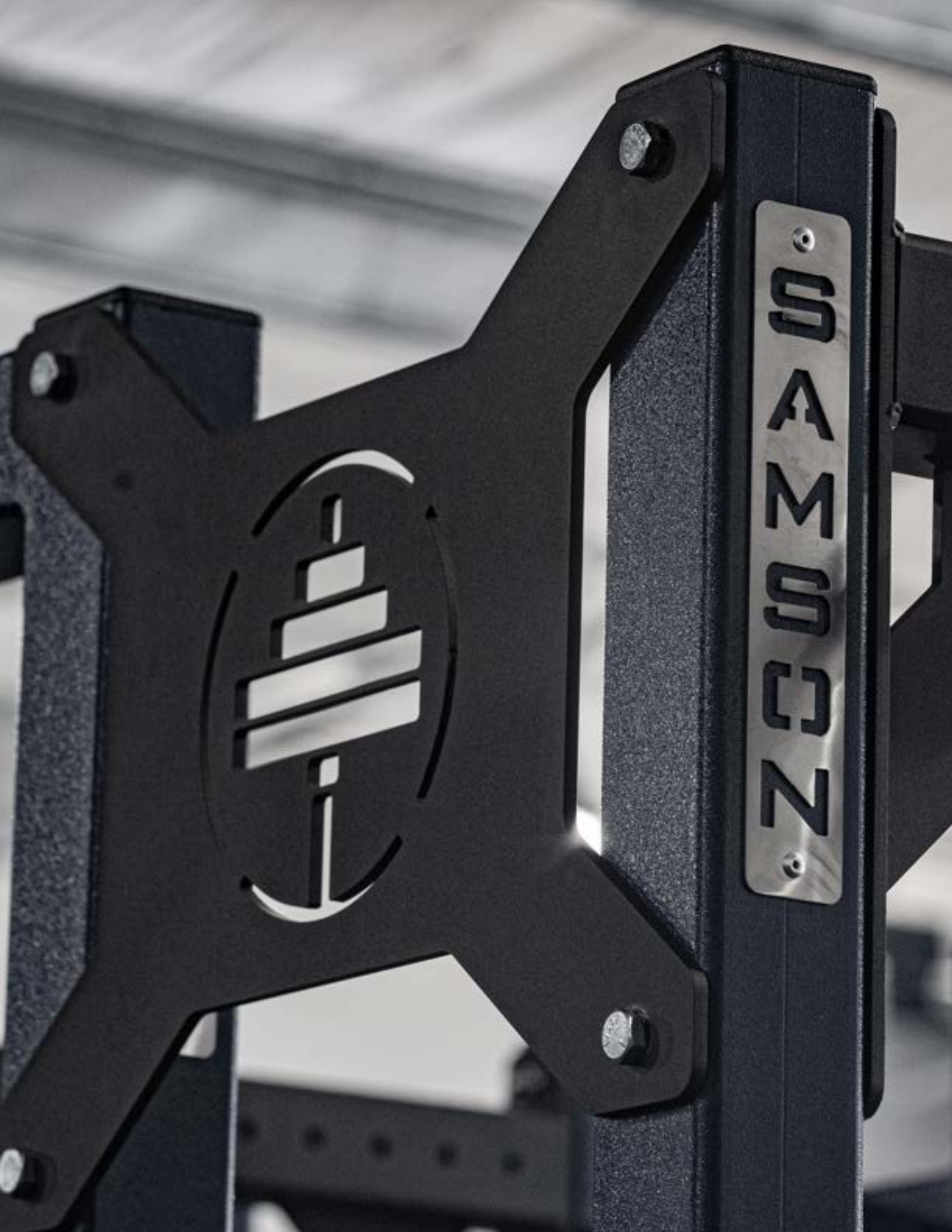

FT

SAMSON

BUDGET

At Samson, we embrace the responsibility of simplifying your weight room journey. With our decades of experience, we possess the knowledge and expertise to guide you through every consideration, every question, and every challenge. Trust us to be your partners, delivering solutions that go beyond your expectations. Together, we will create a weight room experience that empowers and inspires.

QUESTIONS FOR YOUR CONSIDERATION:

SCOPE OF PROJECT:

Are you envisioning a complete weight room transformation or planning to implement changes in phases? We understand the importance of strategizing the scope of your project to align with your goals and resources. Whether you're seeking a comprehensive overhaul or gradual enhancements, our expertise ensures a tailored approach to meet your unique needs.

FUNDRAISING:

Will fundraising be a part of your weight room project? We understand that securing additional funds may be necessary to achieve your vision. Count on us to provide guidance and support in developing fundraising strategies, leveraging our experience to help you secure the necessary resources to turn your aspirations into reality.

STAGE OF PROJECT:

Are you currently in the planning phase, exploring ideas, or actively in the procurement process? We recognize that each stage demands a different level of guidance and support. As your dedicated partners, we are ready to jump in at any point, offering valuable insights and expertise to help bring your weight room vision to life.

BUDGET PLANNING:

Do you have a budget in place for your weight room project? We recognize the significance of financial considerations and believe in maximizing the value of every dollar you invest. Our team will work closely with you to identify the best solutions that align with your budget, ensuring you receive the highest quality equipment and services that yield exceptional results.



PROGRAMMING

During the initial conversations with our dedicated Sales Team, we invite you to take a seat and engage in a comprehensive discussion about the unique dynamics of your organization's strength and conditioning programming. Our aim is to ensure that your facility operates at its full capacity, delivering unparalleled results.

QUESTIONS FOR YOUR CONSIDERATION:

WHAT IS YOUR ROOM SIZE AND LIMITATIONS?

Understanding the dimensions and limitations of your weight room space is essential for creating an optimized layout and selecting equipment that maximizes functionality and safety while ensuring a seamless flow of movement.

HOW MANY ATHLETES WILL BE USING THE ROOM AT A TIME?

Knowing the expected number of athletes utilizing the weight room simultaneously enables us to design a space that accommodates their needs, ensuring ample room for training, equipment accessibility, and a comfortable environment for focused workouts.

WHAT TYPES OF MODALITIES ARE YOU IMPLEMENTING?

Identifying the specific modalities you plan to incorporate, such as free weights, resistance machines, cardio equipment, or specialized training tools, allows us to curate a comprehensive equipment selection that aligns with your training objectives and optimizes performance.

HOW DOES A TYPICAL SESSION FLOW THROUGH YOUR WEIGHT ROOM?

Gaining insight into the typical flow and structure of a training session within your weight room helps us strategically plan the layout, equipment placement, and flow of movement, ensuring a smooth and efficient experience for coaches and athletes alike.

WHAT WILL MAKE COACHING MORE EFFICIENT FOR YOU?

By understanding the unique coaching needs and preferences within your organization, we can provide solutions that streamline coaching processes, whether it's through equipment features, space optimization, or incorporating technology-driven tools to enhance coaching effectiveness, communication, and athlete monitoring.



EQUIPMENT SELECTION

Following a thorough conversation and evaluation of your unique programming, our dedicated Sales Team will guide you through a comprehensive discussion on equipment options that not only maximize the available space within your facility but also align seamlessly with your programming philosophy. We understand the importance of selecting the right equipment to enhance performance and create an environment that fosters success. Trust us to provide tailored solutions that bring your vision to life.

QUESTIONS FOR YOUR CONSIDERATION:

HOW MANY ATHLETES WILL BE USING THE ROOM AT A TIME?

We value your input and understand the importance of specific equipment to support your training goals. By identifying your non-negotiable pieces, we can prioritize and ensure that your facility is equipped with the essential tools vital to your programming success, allowing you to unleash the full potential of your athletes.

ARE THERE ANY CUSTOM PIECES NECESSARY TO EQUIP YOU WITH THE TOOLS YOU NEED?

We recognize that each organization has unique requirements, and sometimes off-the-shelf solutions may not fully meet your expectations. By understanding the need for custom equipment, we can collaborate closely with you to design and deliver tailor-made solutions that align perfectly with your programming philosophy, providing you with the precise tools needed to excel in your training environment.

WHAT ARE YOUR CURRENT PAIN POINTS? THINGS YOU WANT TO DO BUT JUST CANNOT GET DONE.

We genuinely care about overcoming the challenges you face in your training environment. By uncovering your current pain points, we can work together to find innovative solutions and address those obstacles that hinder your progress. Our goal is to empower you to accomplish what you aspire to do, creating an environment where your training ambitions can be fully realized.





2D LAYOUT

Once our dedicated Sales Team has a clear understanding of the equipment required to optimize your room space, we embark on the journey of designing your weight room. Through meticulous 2D layouts, we bring your vision to life, painting a vivid picture of how each piece of equipment will be thoughtfully positioned to ensure safety, functionality, and a seamless flow within your space.

****ROOM SAFETY IS EXTREMELY IMPORTANT AND WE WILL NEVER FIT MORE THAN WHAT IS SAFE IN A ROOM****

This critical step allows you to gain valuable insights into the alignment between your desires and requirements, and the financial considerations of your budget. By exploring this aspect in detail, you will have a comprehensive understanding of how your vision can be realized within the given resources, empowering you to make informed decisions and ensuring that the final solution perfectly balances your aspirations with practicality and fiscal responsibility. Our goal is to guide you through this process, ensuring transparency and empowering you to make the best choices for your weight room project.

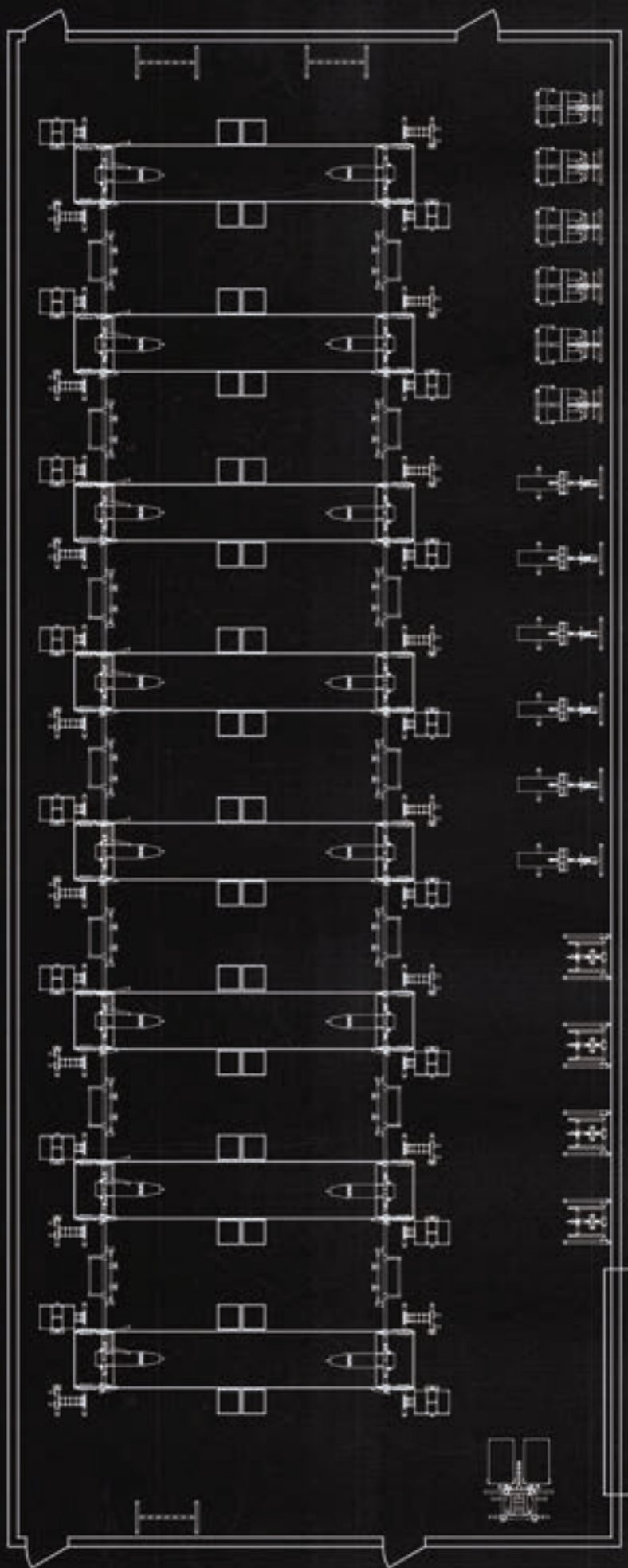

3D LAYOUT

Once your approved 2D layout is in place, we seamlessly transition into the exciting phase of designing immersive 3D renders. With meticulous attention to detail, we create stunning visual representations that provide you with an accurate and captivating preview of how your weight room will look once the installation is complete. This transformative experience allows you to envision the final result, ensuring that every aspect of your room aligns with your vision and aspirations.



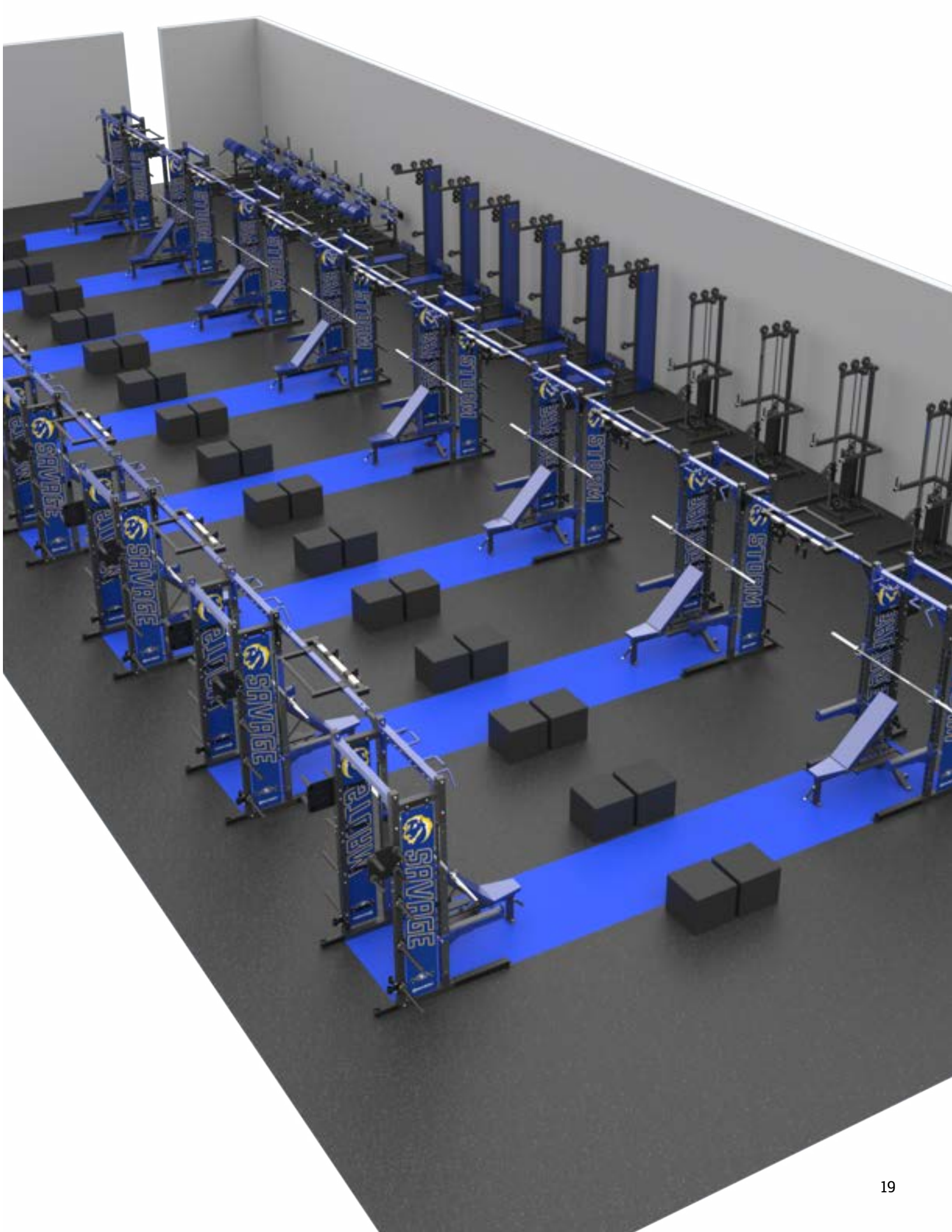

MANUFACTURING

As a build-to-order facility, we take pride in creating custom strength equipment tailored to your specifications. Each job enters our queue, patiently awaiting its turn on the table of our skilled fabricators, ensuring that your equipment is crafted with meticulous attention to detail and precision.

LEAD TIME NOTES:

- Our lead times range from 6 to 8 weeks (subject to change based on workload).
- The availability of third-party procured items may vary.
- Please note that custom-ordered bumper plates, dumbbells, and barbells have increased lead times as they are sourced externally.



HEAVY DUTY STEEL

Our Samson Standard Stamp of Durability, a 3/16" (.188) gauge thick steel wall across all our equipment.



POWDER COAT FINISH

Gives your project a final touch of longevity and personalization.



SEALED BALL BEARINGS

Used to go the extra mile to ensure an extended lifetime on your moveable pieces.



HEAVY DUTY STAINLESS STEEL

Added for aesthetic and function these stainless steel pieces are nearly indestructible when used correctly in your room.



CASE HARDENED STEEL

Reinforced steel rods for durability of load bearing guides.



DELIVERY/INSTALLATION

As your project nears completion within our facility, our dedicated team works diligently to ensure a safe and prompt delivery, followed by a seamless installation process. With a focus on your specific project scope and budget, we offer a range of installation services to meet your unique needs, ensuring a hassle-free experience from start to finish. Count on us to deliver excellence every step of the way.

SEAMLESS DOCK-TO-DOCK SHIPPING:

At Samson, we prioritize a smooth and efficient delivery process. With our dock-to-dock shipping service, we ensure that your equipment is safely transported from our facility to yours. Please note that installation services are not included, allowing you the flexibility to handle the setup according to your specific needs and preferences.

SUPERVISED INSTALLATION:

For enhanced support during the installation process, we offer a supervised installation option. When you choose this service, we ship your order along with one of our knowledgeable Samson Team Members, providing valuable assistance and guidance. While our team member will be there to support you, it is important to note that you are responsible for arranging additional help to assist with the installation. Together, we ensure a collaborative and successful installation experience.

FULL INSTALLATION:

With our comprehensive installation service, we take care of all the necessary arrangements to ensure a smooth and successful installation of your order. Our team will handle coordinating the required assistance, allowing you to focus on providing access to your designated room where our skilled professionals will carry out the installation process. Rest assured, we strive to make the entire experience effortless for you, delivering exceptional results with utmost convenience.



CUSTOM SOLUTIONS

At Samson, we specialize in delivering custom excellence, providing tailored solutions that perfectly fit your specific requirements. From modified racks to specialized storage and one-of-a-kind strength training equipment, we craft unique solutions that bring your vision to life, ensuring optimal functionality and unmatched quality.





CUSTOM BRANDING

At Samson, we understand the significance of identity. That's why we offer custom branding options, including powder coat colors, upholstery choices, branded graphic shields, bumper plates, and dumbbells. These personalized elements reflect your unique affiliation, allowing you to make a lasting impression in your weight room.



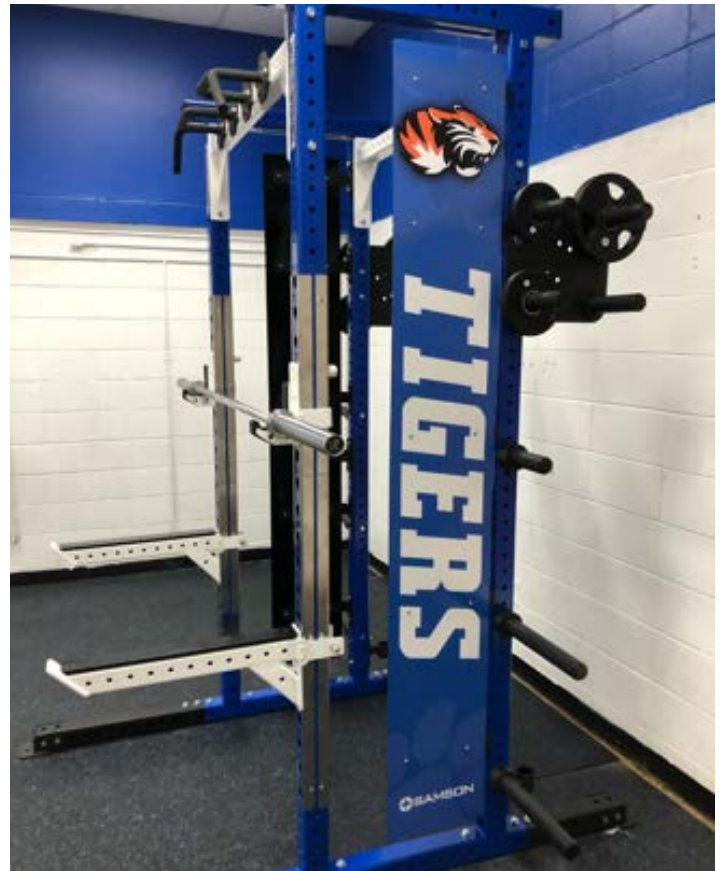

FLOORING

At Samson, our commitment to delivering professional weight room solutions extends beyond mere equipment. We understand that the flooring serves as a critical foundation for creating an exceptional and functional room. Let our expertise be your guide as we assist you in making informed decisions while investing in your flooring. Our knowledgeable experts will assess, educate, and recommend the optimal flooring solution tailored to your project, ensuring that your weight room stands on the firmest foundation for success.

- EVALUATE:** We take a look at your current flooring situation, your budget, and your needs.
- EDUCATE:** We provide honest feedback and options for you to choose from.
- ENDORSE:** We recommend flooring solutions and assist in getting your flooring installed prior to our delivery.



ULTIMATE RB™
A CARLISLE COMPANY

ecore™

REGUPOL



Basha High School - Chandler, AZ

FLEX SERIES



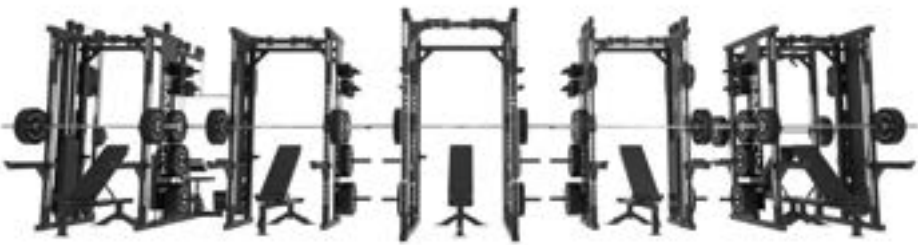

EXERCISES



FLEX-RACK



Introducing our revolutionary Patented FLEX-RACK™ Series, a testament to the freedom and flexibility it brings to your weight room design. This cutting-edge Rack Series is carefully crafted with long-term goals and budget-consciousness at its core. Experience the power of innovation as you unleash the full potential of your weight room without compromising on quality or budget.

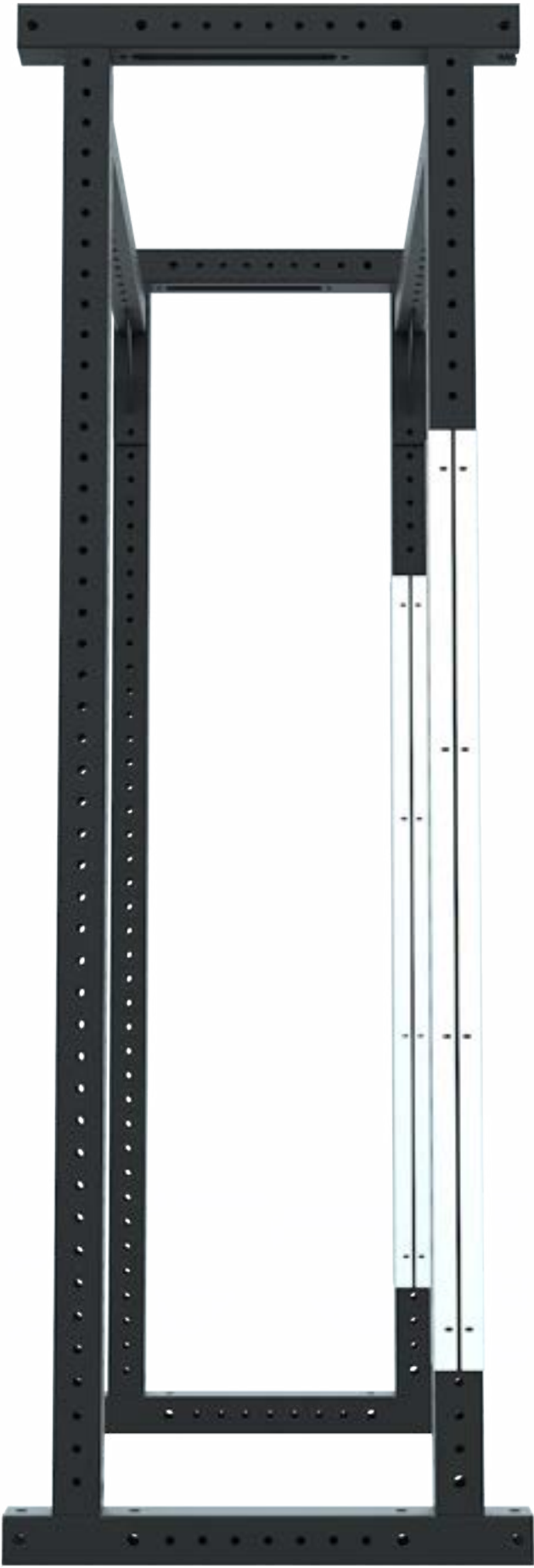

BASE FRAME

At Samson, our foundation frame allows you to FLEX your rack design into any of our FLEX models, unlocking endless possibilities for your weight room layout. Embrace flexibility and maximize your space for years to come.

- Steel Size 3"x3" 7 gauge .188
- Depth - 32.5 in
- Width - 50 in
- Height - 99 in
- Mass - 357 lbs
- Rack Holes - 1.44 in

99"



50"

HALF-RACK

Introducing the Samson Half-Rack, powered by our Flex-Rack frame. It boasts 3"x3" 7-gauge .188 steel for unparalleled strength. The 78x50 inches footprint offers ample space while conserving room. Complete with Samson stainless shield rack guards for both protection and aesthetics. Elevate your strength training with this versatile powerhouse.

Steel Size: 3"x3" 7 gauge .188

Depth: 78 in

Width: 50 in

Height: 99 in

Mass: 640 lbs

Rack comes with Stainless Steel Upright Shields, Standard Samson Chin Up Handles, Plate Storage, Safeties, and J-Cups.

****Graphic Shields Sold Separately****



DOUBLE-RACK

Presenting the Samson Double-Rack, a powerhouse of strength and versatility, built on our robust Flex-Rack frame with 3"x3" 7-gauge .188 steel. With a spacious depth of 113 inches and a width of 83 inches, it allows athletes to lift from both sides simultaneously, maximizing lifting zones in a compact footprint. Experience enhanced efficiency and accommodate more athletes with the Samson Double-Rack, the ultimate solution for high-performance weight rooms.

Steel Size: 3"x3" 7 gauge .188

Depth: 113 in

Width: 83 in

Height: 99 in

Mass: 831 lbs

Rack comes with Stainless Steel Upright Shields, Standard Samson Chin Up Handles, Plate Storage, Safeties, and J-Cups.

****Graphic Shields Sold Separately****



POWER-RACK

Introducing the Samson Power-Rack, the ultimate all in one built on our Flex-Rack frame and fortified with 3"x3" 7-gauge .188 steel for ultimate durability. With its 67.5x83 inches dimensions, it offers ample space and our heavy duty safeties, providing confidence during squats. Elevate your lifting experience with the Samson Power-Rack, designed for maximum performance and security.

Steel Size: 3"x3" 7 gauge .188

Depth: 67.5 in

Width: 83 in

Height: 99 in

Mass: 692 lbs

Rack comes with Stainless Steel Upright Shields, Standard Samson Chin Up Handles, Plate Storage, Safeties, and J-Cups.

****Graphic Shields Sold Separately****



FUNCTIONAL TRAINING RACK

The Samson FTR (Functional Training Rack), the epitome of efficiency and functionality, featuring our renowned Flex-Rack frame. This innovative rack is equipped with a weight stack and cable columns off the front, allowing you to perform a diverse range of functional exercises without the need for additional equipment. Say goodbye to clutter and hello to a streamlined weight room as the Samson FTR combines strength training and functional fitness in a space-saving design.

Steel Size: 3"x3" 7 gauge .188

Depth: 78 in

Width: 83 in

Height: 105 in

Mass: 1302 lbs

Rack comes with Stainless Steel Upright Shields, Standard Samson Chin Up Handles, Plate Storage, Safeties, and J-Cups.

****Graphic Shields Sold Separately****



FUNCTIONAL TRAINING RACK-COMBO

The Samson Functional Training Rack-Combo, the ultimate solution for comprehensive functional training. With cables running off the back and a specialized lat-row machine attached to one of the posts, this rack offers unparalleled versatility and efficiency in your weight room. Experience the freedom to perform a wide range of functional exercises and target specific muscle groups with ease.

Steel Size: 3"x3" 7 gauge .188

Depth: 99.5 in

Width: 83 in

Height: 105 in

Mass: 1450 lbs

Rack comes with Stainless Steel Upright Shields, Standard Samson Chin Up Handles, Plate Storage, Safeties, and J-Cups.

****Graphic Shields Sold Separately****

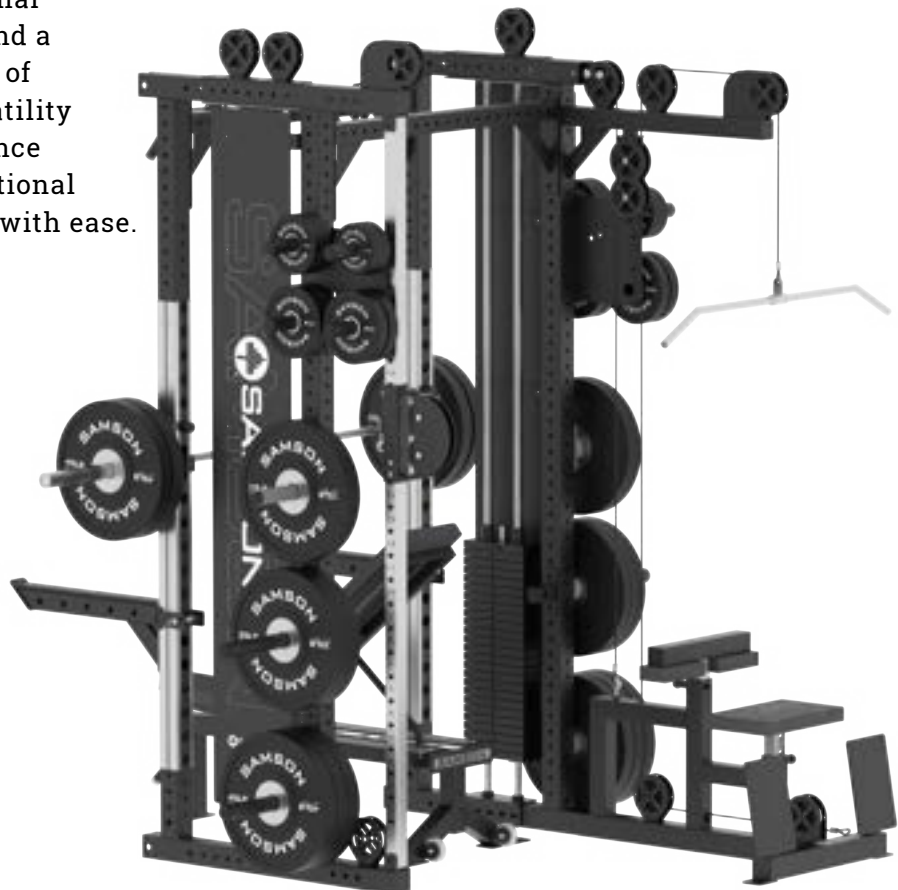

FUNCTIONAL TRAINING RACK REAR

Experience the best of both worlds with the Samson FTR (Functional Training Rack). Our ingenious design allows you to utilize the front of the rack for traditional weightlifting exercises like bench press and squats, while the back features weight stacks and cable columns for dynamic functional exercises. This unique setup enables multiple athletes to work out simultaneously, optimizing your weight room's efficiency and creating a seamless training environment.

Steel Size: 3"x3" 7 gauge .188

Depth: 78 in

Width: 83 in

Height: 105 in

Mass: 1302 lbs

Rack comes with Stainless Steel Upright Shields, Standard Samson Chin Up Handles, Plate Storage, Safeties, and J-Cups.

****Graphic Shields Sold Separately****



J-Cup designed with 1/2" thick UHMW (ultra high molecular weight polyethylene) plastic and seamless roll pin joints to protect your barbells from damage.

Utility Safety Catch design made to incorporate later attachment additions. 1/2" thick UHMW (ultra high molecular weight polyethylene) top protects your barbells from damage.

RACK ATTACHMENTS



DIP RACK ATTACHMENT

J-Cup designed with 1/2" thick UHMW (ultra high molecular weight polyethylene) plastic and seamless roll pin joints to protect



BAND ATTACHMENT

Utility Safety Catch design made to incorporate later attachment additions. 1/2" thick UHMW (ultra high molecular weight



MALAK SWIVEL ATTACHMENT

Utility Safety Catch design made to incorporate later attachment additions. 1/2" thick UHMW (ultra high molecular weight



JAMMER ARMS

J-Cup designed with 1/2" thick UHMW (ultra high molecular weight polyethylene) plastic and seamless roll pin joints to protect



VIKING ATTACHMENT

Utility Safety Catch design made to incorporate later attachment additions. 1/2" thick UHMW (ultra high molecular weight



SINGLE LEG ATTACHMENT

Utility Safety Catch design made to incorporate later attachment additions. 1/2" thick UHMW (ultra high molecular weight



STEP UP ATTACHMENT

J-Cup designed with 1/2" thick UHMW (ultra high molecular weight polyethylene) plastic and seamless roll pin joints to protect



TECHNIQUE SCOOPS

Utility Safety Catch design made to incorporate later attachment additions. 1/2" thick UHMW (ultra high molecular weight



POWDER COAT COLORS:

Meticulously crafted to withstand the test of time and the rigor of any bustling weight room environment. Our powder coat is not just a mere coating; it's a resilient armor that fuses with the steel, creating a robust and long-lasting shield against wear and tear. Even with continuous use, our powder coat maintains its vibrant hues, ensuring your weight room remains an inspiring space for years to come. From intense workouts to daily wear, our powder coat is engineered to endure, exemplifying the epitome of durability and high-quality craftsmanship.



Color Disclaimer: The colors you see above vary across printing and powdercoating and may not accurately portray the correct tint or shade. All Powder Coat comes with a River Texture. **More Colors available for an added cost, ask your Sales Specialist for more information**



RAL 6028

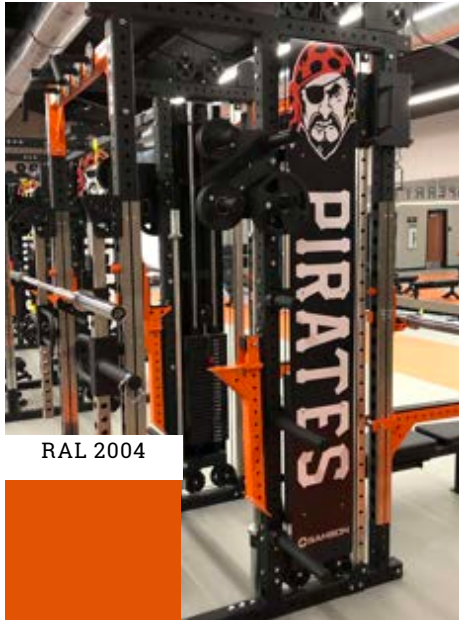

RAL 2004



RAL 6024



RAL 5003



RAL 5003



RAL 5013



RAL 2009



RAL 7005



RAL 3002



RAL 1023



UPHOLSTERY COLORS:

Choose from a wide array of stunning 40oz Texhyde Premier Vinyl colors, all at no extra cost! Our durable upholstery is engineered to withstand the toughest training sessions and endless sweat, ensuring your weight room remains a symbol of excellence for years to come.



Color Disclaimer: The colors you see above vary across printing and powdercoating and may not accurately portray the correct tint or shade.



UPHOLSTERY COLORS:



T08 Sand



T43 Bisque



T07 Camel



T34 Beige



T108 ISO Brown



T130 Pottery



T63 Teal



T36 Aqua



T45 Copenhagen



T75 Emerald



T190 Dragonfly



M39 Gingersnap



T17 Wine



T170 Copper



T65 Black Cherry



T58 Plum



T48 Jade



T87 Pastel Green



T82 Mint



T83 Mist Green



T74 Dusty Jade



T59 Pumpkin



T21 Burnt Orange



T102 Burnt Sienna



T109 Luggage Tan



M94 Toast



T54 Platinum



T79 Medium Grey



T103 Dark Chocolate



T150 Shadow Grey



T01 Black



T160 Tigermoth



T100 Moss



T140 Sage



T104 Fern



T106 Green Apple



T62 Steel Grey



T110 Nickel



T77 Light Grey



T61 Soft Gray



T10 White

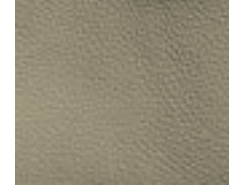

T48 Silver



T76 Grape

Color Disclaimer: The colors you see above vary across printing and powdercoating and may not accurately portray the correct tint or shade.



PRODUCTS





PRODUCTS

SAMSON COMBO BENCH

Introducing our versatile all-around bench, designed to meet your unique needs. From flat to 90 degrees, experience the exceptional adjustability of our Samson Standard bench. Built with .188 Gauge Steel, it exemplifies strength and durability, offering upgrade options and add-ons to enhance your weight room experience.

Depth: 58.25 in
Width: 28.25 in
Height: 19.5 in
Mass: 144 lbs



SAMSON COMBO BENCH WITH VERTICAL STORAGE

Our all-around bench adapts from flat to 90 degrees, offering versatility tailored to your needs. Equipped with Spotter Plates and Anti-Skid Powder Coat, it ensures optimal spotting during overhead lifts. With a space-saving Vertical Storage Bracket and crafted from our Samson Standard .188 Gauge Steel, our bench embodies strength and durability. Elevate your weight room with the ultimate bench solution.

Depth: 58.25 in
Width: 28.25 in
Height: 19.5 in
Mass: 160 lbs





SAMSON FLAT BENCH

A flat bench pad with wheels. Our Samson Standard .188 Gauge Steel on all your tubing applies to our benches as well.

Depth: 57.5 in
Width: 28.25 in
Height: 19.5 in
Mass: 135 lbs



SAMSON COMBO DECLINE BENCH

The decline bench adds variety to your upper body bench pressing. Our Samson Standard .188 Gauge Steel on all your tubing applies to our benches as well.

Depth: 63.5 in
Width: 28.25 in
Height: 26 in
Mass: 165 lbs



SAMSON STANDARD UPHOLSTERY

At Samson, we prioritize the highest quality upholstery for our benches, reflecting our commitment to excellence. Our bench upholstery is meticulously crafted to deliver unmatched durability, comfort, and support. Trust in our unwavering dedication to superior craftsmanship as we strive to provide you with an exceptional bench experience that exceeds your expectations.



SAMSON BARBELLS

Our barbells are manufactured with extreme care and diligence to provide you with great lifting experience. We provide a variety of barbells to choose from.





See our website www.samsonequipment.com for more information and barbell selections.

SAMSON PLATES & DUMBBELLS

URETHANE

Our Competition Bumper plate line for elite level training environments.

Available for Custom Branding

RUBBER

Our Rubber Bumper Plates provide a great solution for high use training environments.

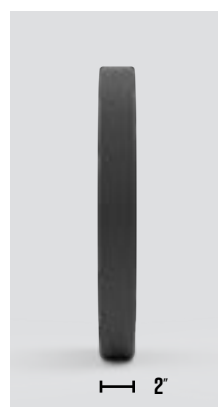
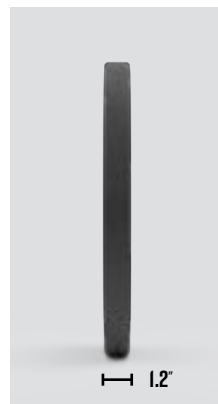
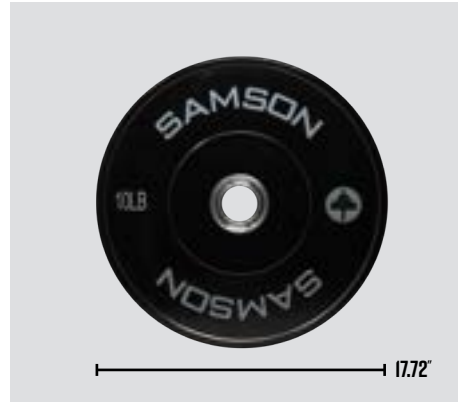
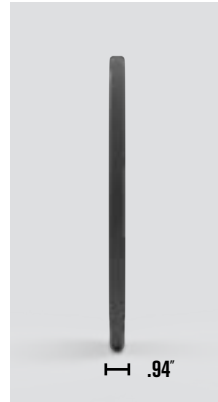
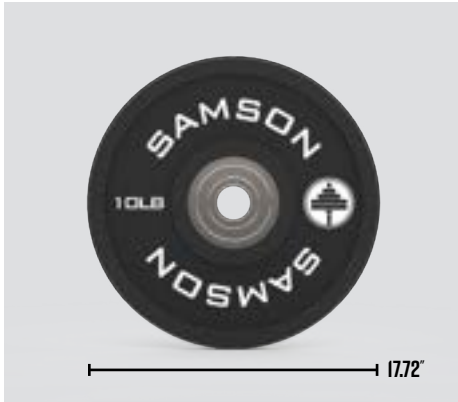

ECONOMY

Our Economy Bumper Plate line are a great solution for anybody.

CHANGE PLATES

Our Urethane and Rubber Change Plates solutions help fill weight gaps and create training loads you need.

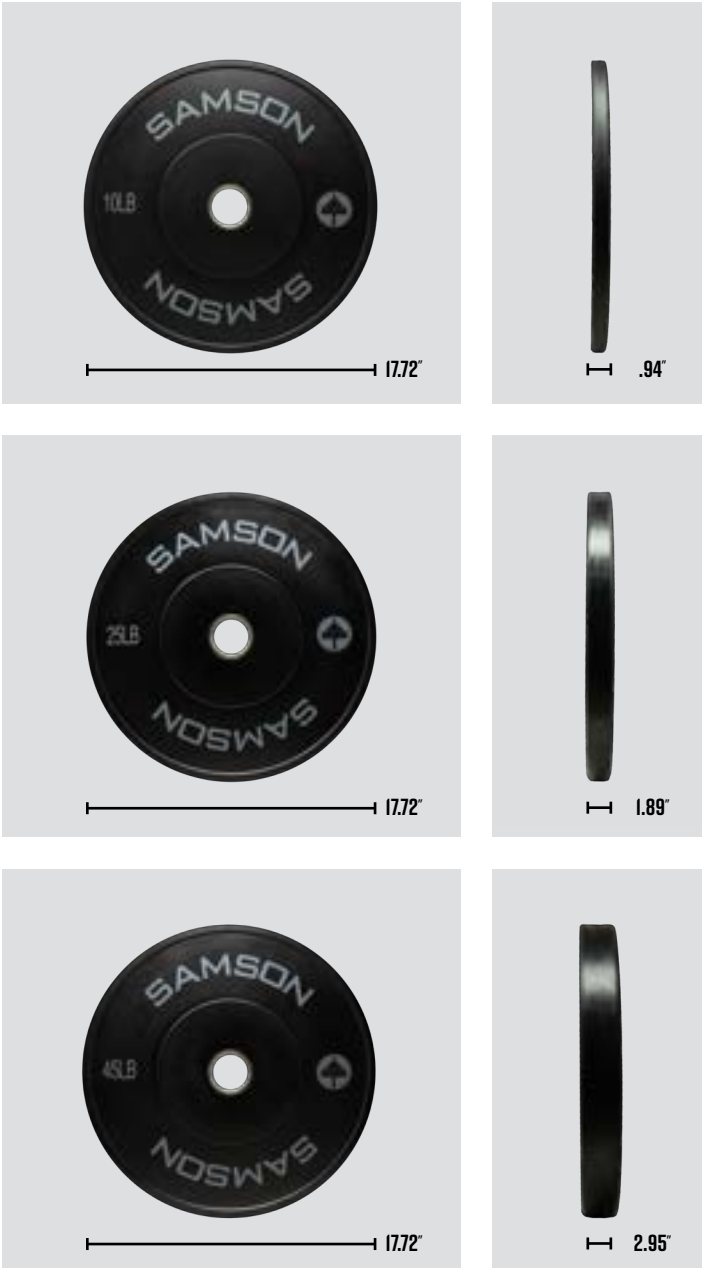

URETHANE

RUBBER



2.5LB

WIDTH - 22.5MM
DIAMETER - 171MM

2.5LB

WIDTH - 26MM
DIAMETER - 159MM



5LB

WIDTH - 25MM
DIAMETER - 200MM

5LB

WIDTH - 28MM
DIAMETER - 184MM



10LB

WIDTH - 36MM
DIAMETER - 227MM

10LB

WIDTH - 41MM
DIAMETER - 244MM

SAMSON DUMBBELLS

As Samson Equipment, we take pride in the superior craftsmanship of our products. Our dumbbells feature polyurethane heads, known for their durability and resistance to wear and tear. The handles are zinc-plated and knurled, ensuring a secure and comfortable grip during your workouts.

Custom Branding Available – We offer the option to personalize these dumbbells with your branding, making them not just a piece of equipment, but a part of your identity.





SAMSON GLUTE HAM DEVELOPER

An Industry Standard GHD with adjustable tubing for biomechanically correct positions. Stainless Steel adjustable tubes provide longevity and protect material. An adjustable knee pad allows for training of athletes at different levels.

Depth: 62 in
Width: 32.5 in
Height: 54 in
Mass: 325 lbs



SAMSON GLUTE HAM/REVERSE HYPEREXTENSION

This device is built around our standard GHD to minimize footprint while utilizing the front of our GHD pad for Reverse Hyperextension exercise. Built with anatomically correct hinge points you feel load throughout your whole movement.

Depth: 70 in
Width: 34 in
Height: 56 in
Mass: 378 lbs





SAMSON FREE STANDING HI-LOW CABLE COLUMN

A free standing selectorized weight stack cable column built for a variety of upper body and lower body exercises. This compact design adds maximum versatility for your space. Weight stack starts at 250lbs.

Depth: 40 in
Width: 38 in
Height: 97 in
Mass: 588 lbs



SAMSON LAT-ROW MACHINE

This machine comes standard with a substantial 300lb selectorized weight stack, crafted entirely from robust steel for enduring reliability. Its dual-function design allows users to efficiently switch between lat pulldown and rowing exercises, maximizing both space and workout potential. The weight stack's selectorized feature ensures seamless weight adjustments, catering to a wide range of strength levels and workout intensities.

Depth: 72 in
Width: 28 in
Height: 96 in
Mass: 640 lbs



SAMSON LEG CURL/LEG EXTENSION

Expertly designed for dual functionality, it allows for seamless transitions between leg curls and extensions, targeting both quadriceps and hamstrings. Its ergonomic design ensures comfort and proper form, while the robust construction guarantees durability. This machine offers precision resistance adjustments, making it a perfect fit for users at any fitness level.



Depth: 65 in
Width: 33 in
Height: 73 in
Mass: 637 lbs

SAMSON BELT SQUAT

The Samson Standard Belt Squat is a state-of-the-art machine, meticulously designed with the specific purpose of aiding in the rehabilitation of athletes, guiding them safely back to their normal loading capacities and full range of motion. Developed in collaboration with Master Level Strength Coach Don Decker, this equipment is a testament to our dedication to superior design and functionality. It not only offers an effective path to recovery but also introduces a valuable dimension to lower body training regimens.



Depth: 78 in
Width: 65.5 in
Height: 57.75 in
Mass: 658 lbs

SAMSON SEATED LEG CURL/LEG EXTENSION

The Samson Seated Leg Curl/Leg Extension machine exemplifies our commitment to versatile and effective strength training solutions. Expertly engineered to target key lower body muscle groups, this machine offers the convenience of performing both leg curls and leg extensions from a comfortable seated position. Its robust design ensures stability and durability, while the easily adjustable settings allow for seamless transitions between exercises.

Depth: 36 in
Width: 36 in
Height: 75 in
Mass: 512 lbs

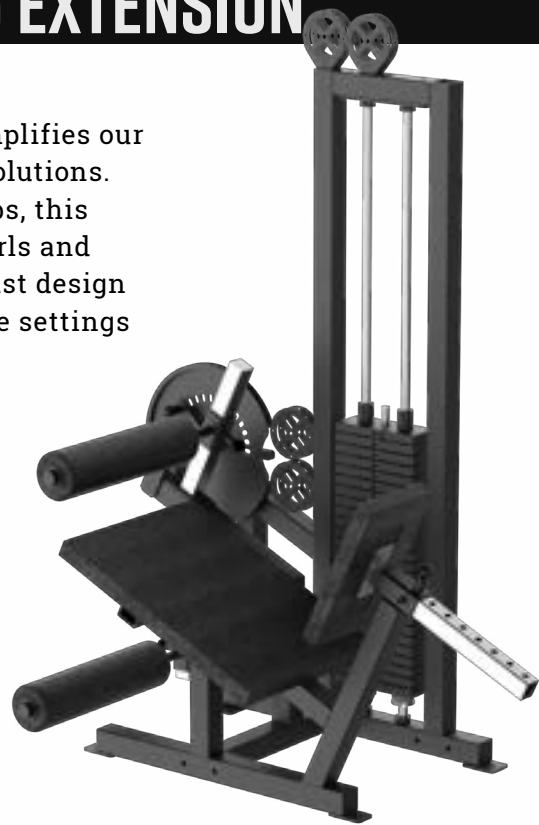

BILATERAL/UNILATERAL HIP SLED

This machine comes standard with a substantial 300lb selectorized weight stack, crafted entirely from robust steel for enduring reliability. Its dual-function design allows users to efficiently switch between lat pulldown and rowing exercises, maximizing both space and workout potential. The weight stack's selectorized feature ensures seamless weight adjustments, catering to a wide range of strength levels and workout intensities.

Depth: 94.13 in
Width: 61.4 in
Height: 62.14 in
Mass: 1657 lbs

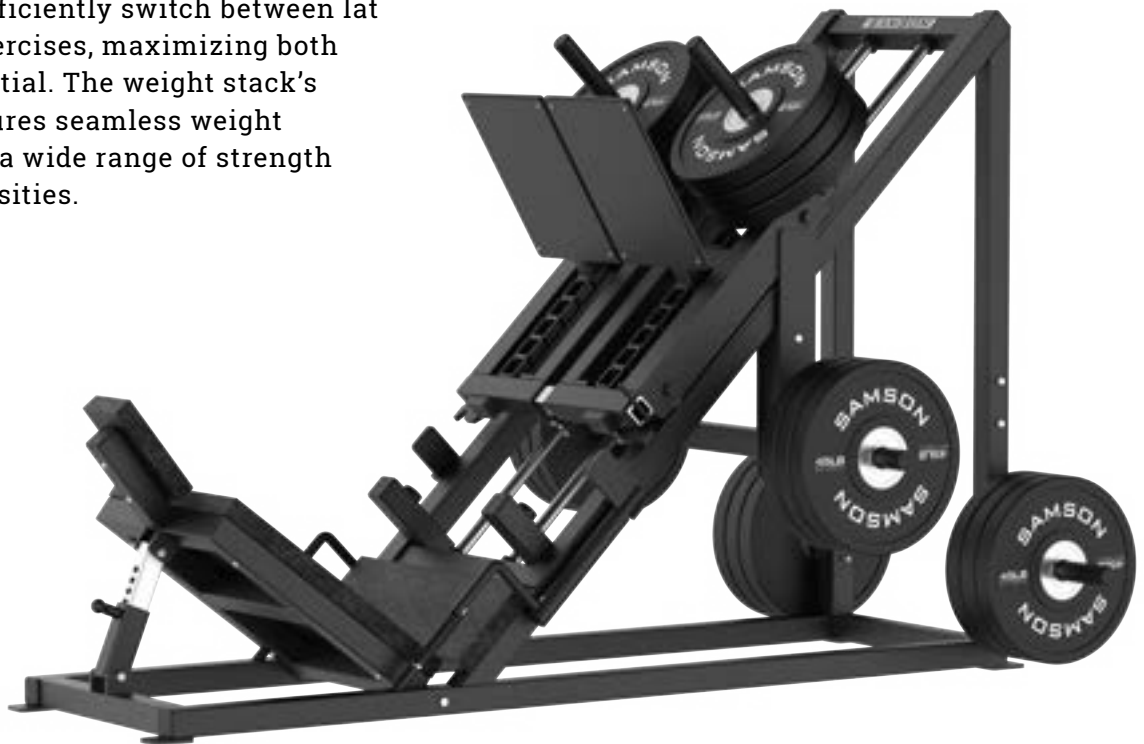



TACTICAL

Tactical Solutions in our industry have grown tremendously in recent years. We took time to study the market to understand and know exactly what we needed to create on our own. Our Samson Brand is built on a strong foundation of providing durable and long term solutions for our customers. Samson Lockers and Samson Outdoor Lifting System® are no different from our Professional Weight Room Solutions. We provide a professional service behind our products that ensures you make the best purchase decision possible. We make ease of purchase happen for our government partners. Utilize your GPC, your ADS rep or our GSA Contract to procure equipment needs!

SAMSON FREEDOM LOCKER



The Samson Freedom Locker allows you to utilize your existing container, or purchase containers from us to easily store your racks, benches, barbells, and weights. Compared to other brands on the market, it is highly configurable to fit your needs. It has a higher capacity with our rack designs. The Samson Lockers are not limited to the foundation of the container, which allows for more mobile rack setups and more freedom of choice for you.

SAMSON OUTDOOR LIFTING SYSTEM (S.O.L.S)



Our Samson Outdoor Lifting System® (S.O.L.S) provides you with a 10' x 10' leveling platform built with Samson Specs at 3"x 3" .188 square tubing frame, 1.5" x 1.5" cross pieces, and a rubber lifting surface. This system is equipped with a 10' x 10' Alaska Structures® Shade tent built to withstand wind speeds of up to 100mph! Take your outdoor training to a new level with this solution.

**** Tent Available for Custom Branding ****

FACILITIES





FACILITIES



SOUTHEASTERN OKLAHOMA STATE UNIVERSITY

DURANT, OK





ZACH FEARS
STRENGTH AND CONDITIONING COACH

“Find someone that knows what they are doing, that’s not just trying to sell you equipment. Get someone that’s set up major rooms and go look at the rooms that they have done. I can tell you right now, Samson will work with you in any way. If you want something customized they are going to do it that exact same way. If you are looking for quality equipment then Samson is your go to!”









UNIVERSITY OF WEST FLORIDA

PENSACOLA, FL





KENT MORGAN
DIRECTOR OF SPORTS PERFORMANCE

“We had certain needs in our weight room that I couldn’t get elsewhere. Samson immediately sent me some 3D layouts, and from that moment on, I was sold. Those were the racks I wanted, and no other companies I had worked with did anything like that. In this facility, you’re basically unlimited as a strength coach on what you can do. I would put it up there with the best in the country. Anyone can walk into our facility and see that nobody else has these racks. They were custom designed especially for all the things I was looking to do - utilizing space, having storage in the racks, and creating a visual effect. We’ve gotten many recruits already, and a lot of the reason is because of Samson Equipment.”

UNIVERSITY OF WEST FLORIDA | PENSACOLA, FL









STALEY HIGH SCHOOL
KANSAS CITY, MISSOURI





STEVE RAMPY
HEAD FOOTBALL COACH

“Samson’s people are so good about looking at your space, looking at your needs, looking at what you want to get done in that space and helping you utilize that both financially and with the space itself...The most important thing was they communicated with us throughout the whole process, we knew where everything was and what date we could expect it to be here and they fulfilled their promises...Give Samson a chance you know, they are so customer friendly like I’ve said I’ve been blessed to do three rooms with these guys and they are so accommodating and so service friendly... Customer service matters to me and they stand behind their product and they make sure they’ll work at it till you get it right.”

STALEY HIGH SCHOOL | KANSAS CITY, MISSOURI









ADDRESS HIGH SCHOOL

EL PASO, TX





JEFF WOODRUFF

ATHLETIC DIRECTOR/HEAD FOOTBALL COACH

“There’s a lot of small colleges who would love to have something like this...The people I’ve talked to around the country, colleges specifically, they spoke highly of the product and durability. It holds up...Everyone in El Paso is going to want to build something now, and if you’re not going with Samson you’re just building a building”

ANDRESS HIGH SCHOOL | EL PASO, TX







ADDRESS
HIGH SCHOOL

 **SAMSON**



SAINT MARY'S COLLEGE

MORAGA, CA





MAX BAYER
ASSISTANT ATHLETIC DIRECTOR

“Our new state-of-the-art Sports Performance Center will help us build resilient, confident student-athlete leaders in a positive and inspiring training environment. The atmosphere will be special and we’ll have more tools than ever before to develop champions.”

SAINT MARY’S COLLEGE | MORAGA, CA









UNIVERSITY OF COLORADO BOULDER

BOULDER, CO





STEVE ENGLEHART
ASSITANT ALTHLETIC DIRECTOR

“Samson worked tirelessly with us on the design of our equipment. Not only did they outfit us with custom-branded racks, DB’s and plates that looked great aesthetically, they went the extra mile to make sure each piece of equipment was designed to meet the functional needs of all our teams and coahces. Their willingness to design custom pieces of equipment that would make huge positive impacts on our training at CU really sets them apart in the industry. We couldn’t be any happier with the finished product and owe a huge thanks to Samson for making our weight room the perfect blend of function and style that will serve us perfectly for years to come.”

UNIVERSITY OF COLORADO BOULDER | BOULDER, CO





SAMSON
EQUIPMENT

SAMSON

SAMS

HOLDRAID

WARNING



BUFFALOES

GOLD'S GYM

GOLD'S GYM

ON

WARNING



58TH SPECIAL OPERATIONS WING

KIRTLAND AIR FORCE BASE





JUSTIN SCHWIND
HUMAN PERFORMANCE ADVISOR

“Working with the military it is hard to purchase anything directly. Samson was willing to work with other companies to make the process happen in a timely manner and to get everything we needed. We’ve gone further than I ever imagined or that I’ve ever seen in a weight room. There are things that I never really thought of if I would of just went with a regular joe off the street. With Samson, everything is customizable. It really is crazy to say but your dreams come true. Not just to make it happen but the expertise, and the knowledge from the Samson staff themselves allowed us to get there. You need people with a performance mindset and Samson has that.”

58TH SPECIAL OPERATIONS WING | KIRTLAND AIR FORCE BASE





HUMANS ARE MORE IMPORTANT THAN HARDWARE





MIAMI UNIVERSITY
OXFORD, OH





JAMES CARSEY

ASSISTANT ATHLETIC DIRECTOR FOR HUMAN PERFORMANCE

“It seemed like they really wanted to do something for us. I think it’s that personal touch that really put it over the top. Then once I started looking at the product compared to the other product I was looking at the time, it was a no brainer to go with Samson. It was a great process and I’m super excited.”

MIAMI UNIVERSITY | OXFORD, OH



REDHAWKS







LAWRENCE HIGH SCHOOL

LAWRENCE, KS





STEVE RAMPY
HEAD FOOTBALL COACH

“The strongest thing they offered me was the customizing of what our needs were... They just are so helpful in meeting your needs for your physical space, but then on top of that their customer service is second to none. They make it right.”

LAWRENCE HIGH SCHOOL | LAWRENCE, KS









WIDEFIELD HIGH SCHOOL

COLORADO SPRINGS, CO





JON SHUB
ATHELETIC DIRECTOR

“This room is an old room. It’s been here since the 1990s, so overcoming the challenges and the surprises this type of room comes with, Samson was able to help us figure out creative solutions to the problems we had... Widefield is a powerful and proud community, so this hopefully emulates the pride and the commitment to our community.”

WIDFIELD HIGH SCHOOL | COLORADO SPRINGS, CO









EASTWOOD HIGH SCHOOL

EL PASO, TX





MARCUS DUCHENE
ELEV8 WEIGHT ROOM CONSULTING

“What really turned me on to Samson was the ability to customize what we wanted to do and make sure it was going to fit the space... Samson was easy to work with to help build it out”

EASTWOOD HIGH SCHOOL | EL PASO, TX





FIND AN EXCUSE TO WIN

CSMSON

TRAINERS



FIND AN EXCUSE TO WIN

FIND AN EXCUSE TO WIN

FIND AN EXCUSE TO WIN

OSAI-GEN



THE UNIVERSITY OF NORTHWESTERN-ST.PAUL

ST.PAUL, MN





TAYLOR GISH
STRENGTH AND CONDITIONING COACH

“Working with Samson was an absolute breeze. I had a lot of things in my mind that I thought this space could be. Troy and the team at Samson really helped me put them down on paper with a lot of great ideas.”





10 National Championships
90 National Appearances
181 All-Americans

UNW
EAGLES

UNW
EAGLES

UNW
EAGLES

UNW
EAGLES

NW
EAGLES

191 Regular and
Post Season
Conference Appearance

SAMSON

EAGLE

EAGLE





UNIVERSITY OF MISSISSIPPI

OXFORD, MS





RILEY ALLEN
STRENGTH AND CONDITIONING COACH

“The room helps us on two fronts as far as with our competitors, ones recruiting, all the branding in the room, modern, bright, efficient, that’s going to help a ton. And then secondly, being able to do more with our team in less amount of time.”







JAMES BOWIE HIGH SCHOOL

AUSTIN, TX





LEE HIPPI
STRENGTH AND CONDITIONING COACH

“We talked about our needs and anytime there was a problem, Samson had some solutions and different suggestions about things to solve some of our problems. They were really helpful on figuring things out. It made it real easy for us as coaches to find out what we needed for our program and how we can best design it.”

JAMES BOWIE HIGH SCHOOL | AUSTIN, TX









SECOND BAPTIST SCHOOL

HOUSTON, TX

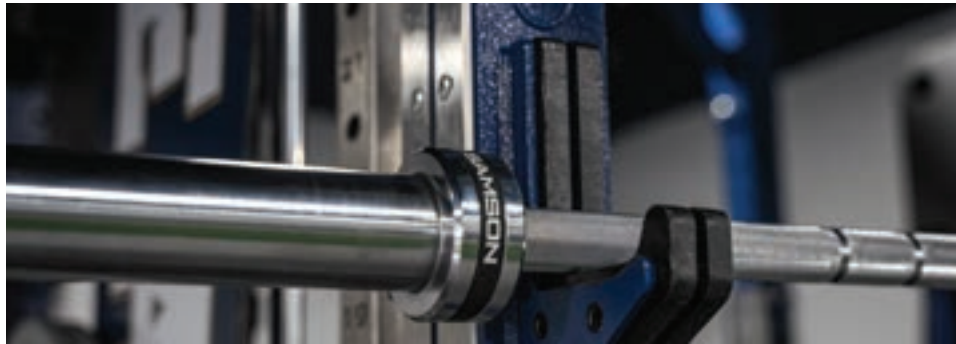



NICK MASCIOLI
HEAD STRENGTH AND CONDITIONING COACH

“We needed to get more students in the weight room, and it’s a dream come true because that’s exactly what’s happening now. The expertise of Samson Equipment has been instrumental in making this happen. Not only do they understand the equipment, but their team includes former strength coaches who understand the vision and platform of how to train students. It’s been a pleasure to work with them and see the results in our weight room.”

SECOND BAPTIST SCHOOL | HOUSTON, TX









BASHA HIGH SCHOOL

CHANDLER, AZ





KAMALEI MAGNANI
HEAD STRENGTH AND CONDITIONING COACH

"I'd say it's something that you would want in any type of elite environment. You can always trust products from Samson... The spacing, the equipment, the overall design, everything about it says that we can be fully functional at every rack so we can do our barbell movements our squatting, cleans and we can bench right there at the same time...Getting in touch with them was easy, I heard back right away, told them what I was looking for, what I wanted, what we have in place and what I'd like to be similar and I thought it was really easy for them because any question that I had he answered it right away. I think that their equipment is solid, it's built to last."

BASHA HIGH SCHOOL | CHANDLER, AZ









DEMING HIGH SCHOOL

DEMING, NM





NICK WILLIAMS
STRENGTH TRAINING COACH

“The Customer service part of that personal relationship was what set Samson apart from other people that I talked to. I just really like the way we have it set up right now, its perfect for what we need and it still enables us in terms of space to add more... The great thing about Samson is that if anything goes wrong everything is under a life-time warranty... Just the customer service part that personal relationship was what set Samson apart from other people that I talked to”

DEMING HIGH SCHOOL | DEMING, NM









WASHINGTON UNIVERSITY

ST. LOUIS, MO

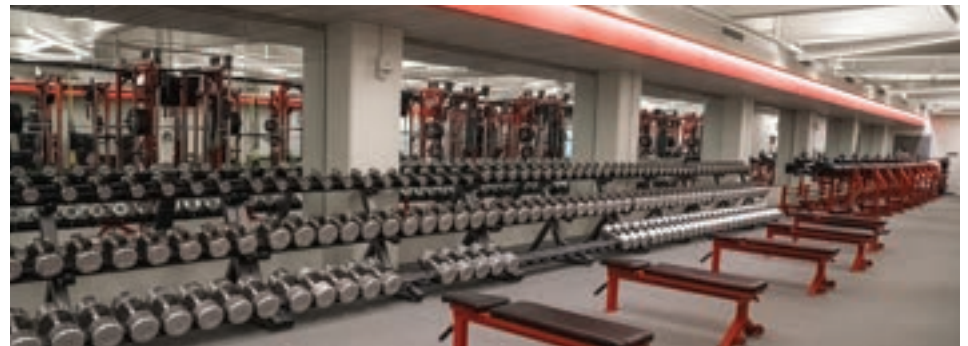



TERRY O'NEILL
SPORTS PERFORMANCE HEAD COACH

“And, you know, their stuff can take the abuse. And obviously from me doing the math both there and here, I mean, when you have 600 athletes that are coming in sometimes four times a week, that’s a lot of wear and tear that’s going to happen on the equipment. So, you know, their reputation preceded them.”

WASHINGTON UNIVERSITY | ST. LOUIS, MO









HOLMES COMMUNITY COLLEGE

GOODMAN, MS





ANDY WOOD
ATHLETIC DIRECTOR

“Well, it first of all, they’ve been doing it for since the seventies and they know exactly what they’re doing. And every piece of equipment they have can be adapted to different things. If we needed to add equipment to it and you could do it instead of having to buy a whole brand new white rack every time you wanted to change something.”

HOLMES COMMUNITY COLLEGE | GOODMAN, MS





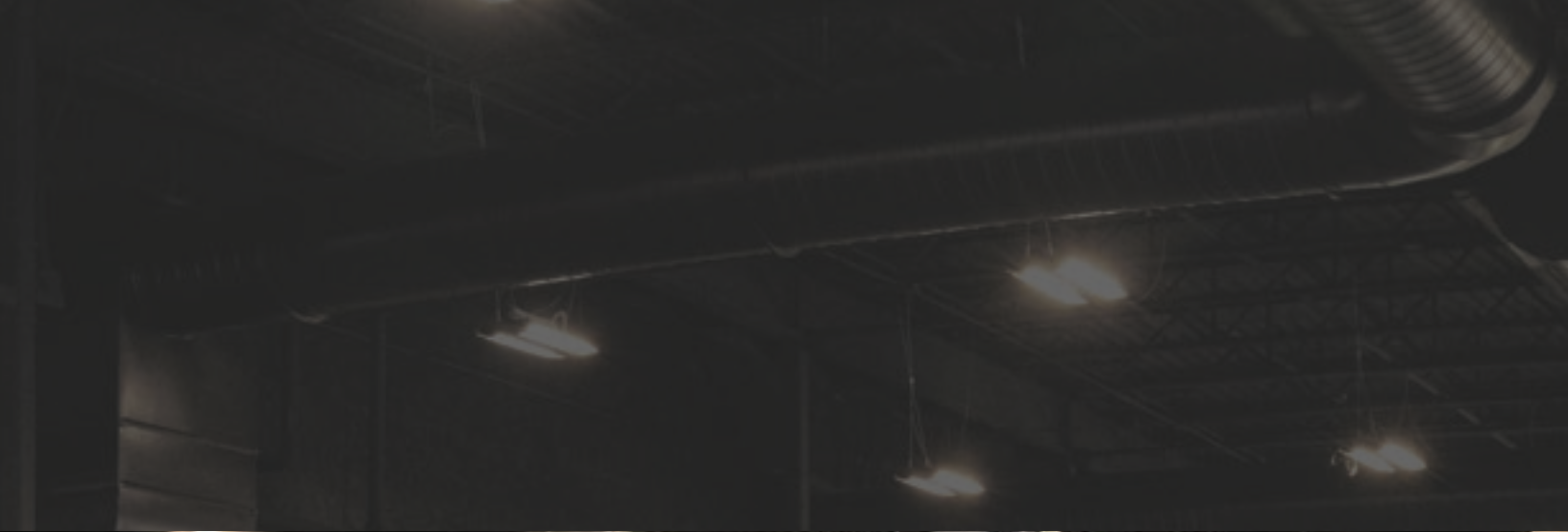



UNIVERSITY OF SOUTH ALABAMA

MOBILE, AL





DAVID VENTRESS
DIRECTOR OF OLYMPIC SPORTS

“It’s been a blessing just to have Samson help us maximize the space and maximize the training that we’re able to do.”

UNIVERSITY OF SOUTH ALABAMA | MOBILE, AL









LOS LUNAS HIGH SCHOOL

LOS LUNAS, NM





GREG HENNINGTON
HEAD FOOTBALL COACH

“Anytime I needed anything, I pick up the phone and call Scott, and he answers it.”

LOS LUNAS HIGH SCHOOL | LOS LUNAS, NM









MESA HIGH SCHOOL

MESA, AZ





JANNA SHROCK
STRENGTH AND CONDITIONING COACH

“Having access to equipment like Olympic bars, bumper plates, and Jammer Arms allows us to train our athletes with the same intensity and professionalism I saw in college.”

MESA HIGH SCHOOL | MESA, AZ









WESTWOOD HIGH SCHOOL

MESA, AZ





BRANDON LARGE
HEAD FOOTBALL COACH

“This facility brings a lot of pride. It’s something our students, coaches, and community can truly be proud of. The equipment we have now is fantastic and serves all our needs, and as our programs grow, we know it will grow with us.”

WESTWOOD HIGH SCHOOL | MESA, AZ









DOBSON HIGH SCHOOL

MESA, AZ





BILL GODSILL
HEAD FOOTBALL COACH

“First day I walked in there, I was like, my job for this is by far the best weight room I’ve ever been in as a high school teacher in the state of Arizona.”

DOBSON HIGH SCHOOL | MESA, AZ









UNIVERSITY OF HAWAII

HONOLULU, HI





TOMMY HEFFERNAN

HEAD STRENGTH & CONDITIONING COACH

“We don’t have the budget a lot of schools have, but we take pride in working hard. We’re here for the right reasons. We love our school, our state, and our teams.”

UNIVERSITY OF HAWAII | HONOLULU, HI









FLORIDA ATLANTIC UNIVERSITY

BOCA RATON, FL





ZANE SCOTT
DIRECTOR OF STRENGTH AND CONDITIONING

“We have to do multiple quotes when you do a room and we have to look at other companies and see which ones best fit. And that was what stood out was the customer service. And then obviously the uniqueness of the actual equipment.”







FLORIDA ATLANTIC





FLORIDA ATLANTIC UNIVERSITY

BOCA RATON, FL





ZANE SCOTT
DIRECTOR OF STRENGTH AND CONDITIONING

“We have to do multiple quotes when you do a room and we have to look at other companies and see which ones best fit. And that was what stood out was the customer service. And then obviously the uniqueness of the actual equipment.”







TESTIMONIALS

Some of the unique things that Samson did in their rack design as well as the NMSU branding they did definitely create conversation for all who enter the new room. The athletes at NMSU have a lot to brag about.

-Don Decker

CCSA CHIEF EXECUTIVE OFFICER | RETIRED NMSU DIRECTOR OF SPORTS PERFORMANCE

Samson Equipment provided elite equipment at an affordable price. We had a short timeline to complete the weight room and Samson met it effortlessly. They were professional, efficient and able to adjust on the fly. The strength staff had a say in every detail and it led to truly customized equipment that reflected our training philosophy. The graphic shields really made the racks stand out. Would definitely work with Samson Equipment again.

-Captain Kevin Quinn

AIR FORCE ACADEMY | COLORADO SPRINGS, CO

I contacted 3 major strength equipment vendors. As time went on it was evident that only one vendor, Samson was willing to be patient enough with the process to continue the lines of communication and offer ideas at different price points. Samson only offers one level of equipment "top of the line" so there would be no shortcuts. Brian Schroeder took the time to facetime me, view the facility and the upstairs hurdles and to most importantly. LISTEN!

-Ted Beyer, Head Strength Coach

RIDGEFIELD HIGH SCHOOL | RIDGEFIELD, WA

"The customer service from Samson was incredible, throughout the entire process, from facility design to install. They were in constant communication and were able to customize all equipment to serve our student athletes' needs. The attention to detail in design and versatility of the equipment will continue to give our student athletes a competitive edge for many years to come."

-Brian Amenta

UNIVERSITY OF MARYLAND, BALTIMORE COUNTY | BALTIMORE, MD

"The Branding and Logos that Samson created for our program really gave our weight room its own unique appeal. The Power Rack stations have allowed our athletes to accomplish so much more from our weight sessions."

-Gary Rundell
MOUNTAIN VIEW HIGH SCHOOL | EL PASO, TX

"Working with Samson was an enjoyable experience, in that, they didn't show you a lot of things and say, "this is what we have", instead they came to us asking, "What do you need?". It was nice not having limitations put on the process of building this weight room."

-Jeffrey Ramirez
DEL VALLE HIGH SCHOOL | AUSTIN, TX

"Opening a new school is a very daunting yet rewarding task, and you want to make sure you get things right from the start. Working with the team at Samson to outfit our weight rooms was the best decision I made. No one can match their product, service, or creativity. What sets them apart from the competition is their ability to design a product based on your needs. Their unique graphics provides an outstanding look to an already great product. There isn't a better weight equipment company out there."

-Cody Moore
BRASWELL HIGH SCHOOL | AUBREY, TX

We placed our first huge purchase with Samson Equipment back in 1985 and are still purchasing from them in 2019, 34 years later. There is a reason for this loyalty. The customization of pieces to fit an institution's facility restrictions and program prescriptions is unparalleled in the industry. If you can dream it, they can make it, and make it amazing.

-Tim McClellan
ARIZONA ARSENAL | MESA, AZ

OUR SPECS. & WARRANTY

SAMSON BUILT FOR STRENGTH WARRANTY:

The steel materials and/or workmanship in SAMSON machines are warranted for Lifetime when used as intended as applicable to the original purchaser (non-transferable). In the event they fail through no abuse or fault of the owner, please notify SAMSON Equipment, Inc. and return the equipment at the owner's expense. SAMSON Equipment, Inc. will repair or replace the equipment at SAMSON'S option, and shall return the same to the owner at SAMSON'S expense.

Customer bears the responsibility of contacting Samson Equipment with the pertinent information as to the condition of the equipment.

Bearings are warranted for 8 years if used as designed and intended and not abused by the owner. All other moveable parts are warranted for 1 year if used as designed and intended and not abused by the owner, as applicable to the original purchaser (non-transferable).

Upholstery/ Powder Coating / Paint is warranted for 18 months if used as designed and intended, and not abused by the owner, as applicable to the original purchaser (non-transferable).

Wood products are warranted for 90 days if used as designed and intended, and not abused by the owner, as applicable to the original purchaser (non-transferable).

Warranty items are subject to inspection by Samson Equipment to determine if warranty-voiding abuse, neglect, or misuse is present. If Warranty-Voiding situation is present, repairs can still be done on a labor and materials required basis. A written estimate and bill will be provided to the customer before non-warranty repairs are done. Customer bears the costs of packaging and return shipping on any non-warranty situation.

Third Party Warranties for products provided but not manufactured by Samson Equipment as warranted by the original manufacturer, such original manufacture's warranty applies solely.

This Samson Built for Strength warranty is an expressed warranty and excludes all other warranties expressed or implied, as applicable to the original purchaser (non-transferable).abused by the owner.

SAMSON BUILT SPECS.

- Most items use ASTM A-500 Gr B 3" x 3" x .188 steel square tubing weighing 7.04 lbs./ft. or ASTM A-500 Gr B 2 1/2" x 2 1/2" x .188 steel square tubing weighing 5.75 lbs./ft. Some items use 2" x 2" x .188 steel square tubing weighing 4.32 lbs./ft. All flat welds are ground, sanded and polished to a smooth finish for appearance. All exposed tube ends are capped.
- All machine cables use 3/16" diameter 7x19 galvanized steel aircraft cable that is nylon coated to 1/4" diameter. Stainless steel thimbles are used for all eyes.
- Heavy duty 40 oz. Expanded Vinyl used on all items requiring upholstery. Choice of colors available. Upholstery corners are stitched, with perimeter double stitching.
- Super 12 lb. density neoprene closed cell padding is used for support. 3/4" plywood is used for support. T-Nut fasteners.
- Baked on Electrostatically Applied Powder Coating having a Specific Gravity of 1.2-1.7g/cm cubed. Cured at 340 degrees for 15 min. after substrate material has reached 340 degrees. Gloss levels to be between 55-65 according to TSO 2813/60 degrees. Available in a variety of basic colors at no additional charge. Applied to a minimum of 3 mils thickness. Surfaces are sand blasted and DA sanded prior to painting.
- 1630 DS precision ground sealed bearings are used at all hinge points. 4 1/2" precision ball bearing pulleys are used on all machines. Samson uses three sizes of Linear Ball Bearing Systems (1 1/2", 1 1/4", & 1" lineal ball bearings); all systems use Rockwell 60 case hardened shafting.
- Spring-loaded pop-pins are used for quick and easy adjusting. Telespar, a snug fitting telescoping square tubing, is used for tight solid feel of stability. All adjustable parts to have brushed finish, made of type 304 stainless steel (with a 400 grit finish) with numbered window system.
- Weight stacks to be made of Steel, no cast iron or other alloy material will be substituted. Steel plates will not break or fracture like alloy or cast iron. All weight stack plates to be painted black with corresponding weight marks clearly visible to the user. Weight plate guide rods are solid 1" round ground steel, Industrial chrome plated. All selector plates are machined steel with machined MDS bushings in every plate and MDS cushioning between every plate. All weights are lifted by 7/8" round solid cold rolled steel selector shafts with bright polished chrome finish. All weight stacks use magnetic selector pin.

